

NTG24064C Graphic 240x64 dots

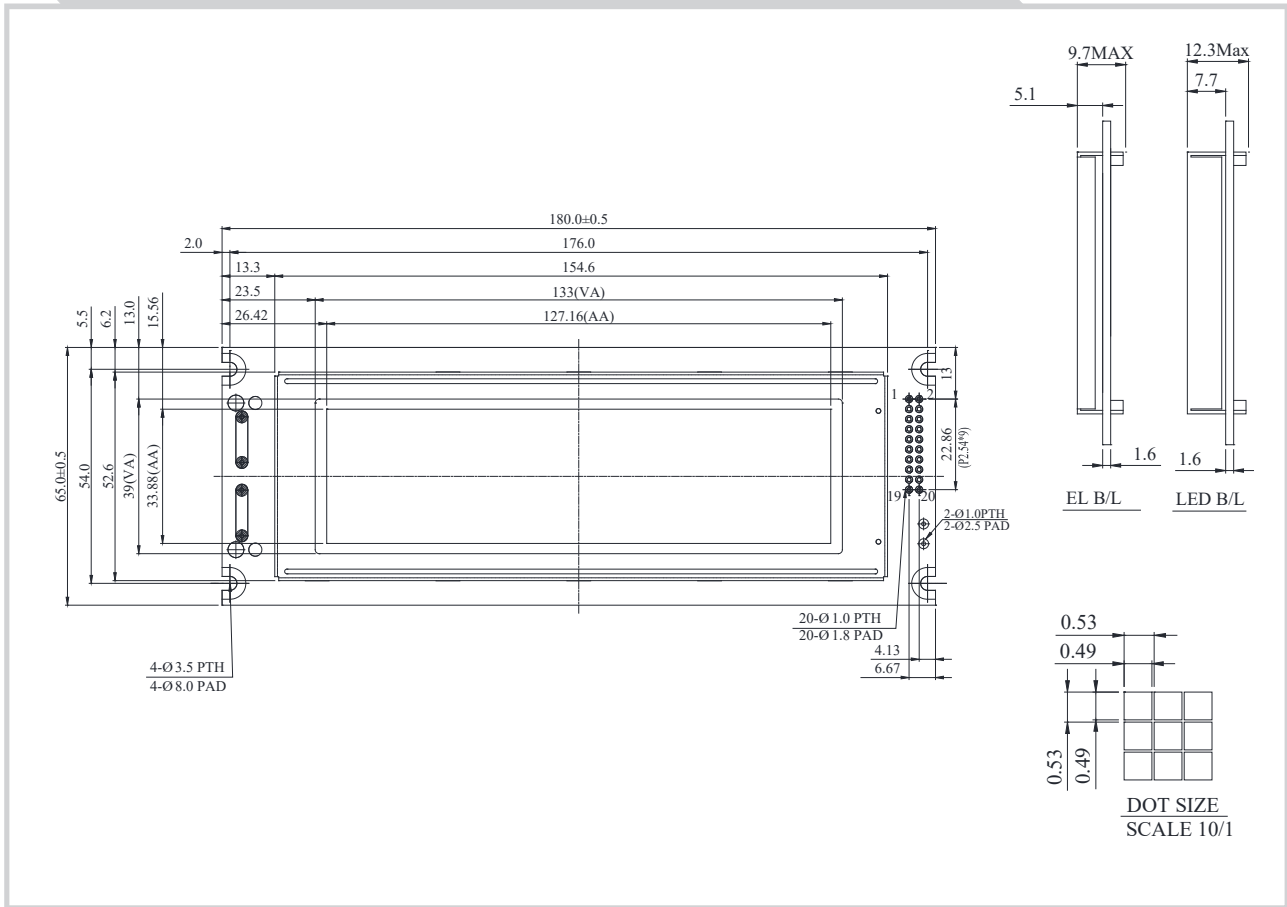

Feature

1. Built-in controller RA6963
2. 5V power supply
3. 1/64 duty cycle
4. Built-in N/V

Pin No.	Symbol	Description
1	FG	Frame ground
2	V _{SS}	Ground
3	V _{DD}	Power supply for logic
4	V _O	Contrast Adjustment
5	/WR	Data write. Write data into LCD Controller
6	/RD	Data read. Read data from LCD Controller
7	/CE	Enable signal
8	C/D	Data/ Instruction select signal
9	V _{EE}	Negative Voltage Output
10	/RESET	Controller reset signal, Active Low
11	DB0	Data bus line
12	DB1	Data bus line
13	DB2	Data bus line
14	DB3	Data bus line
15	DB4	Data bus line
16	DB5	Data bus line
17	DB6	Data bus line
18	DB7	Data bus line
19	FS	Selection of font; H : 6 * 8 , L : 8 * 8
20	NC	No connection

Mechanical Data

Item	Standard Value	Unit
Module Dimension	180.0 x 65.0	mm
Viewing Area	133.0 x 39.0	mm
Mounting Hole	176.0 x 54.0	mm
Dot Pitch	0.53 x 0.53	mm
Dot Size	0.49 x 0.49	mm

Electrical Characteristics

Item	Symbol	Standard Value	Unit
		typ.	
Input Voltage	V _{DD}	3/5	V
Recommended LCD Driving Voltage for Normal Temp. Version module @25°C	V _{DD} -V _O	12.5	V