

NTG240128B Graphic 240x128 dots

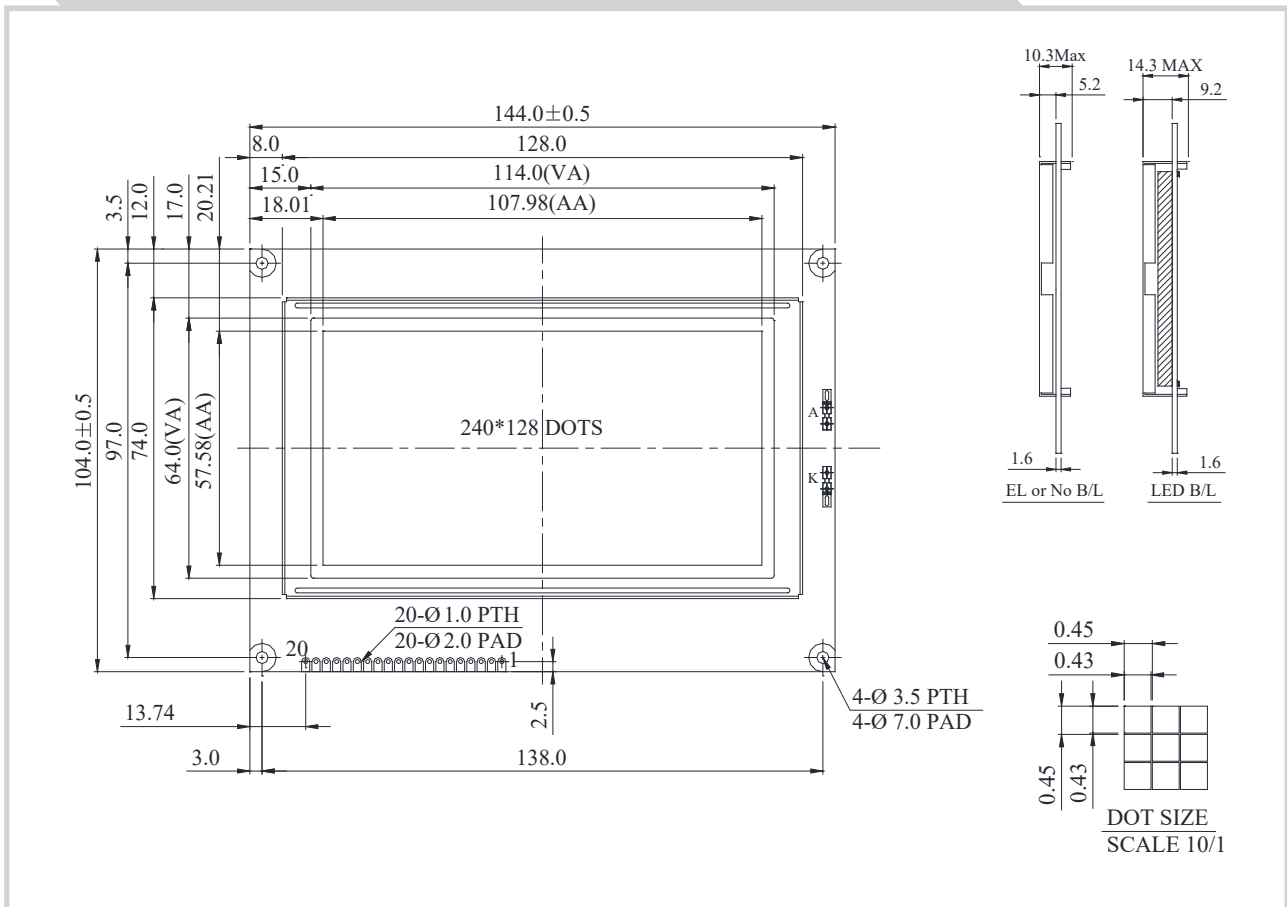

Feature

1. Built-in controller RA6963
2. 1/128 duty cycle
3. Built-in N/V
4. Temperature compensation optional

Pin No.	Symbol	Description
1	V _{SS}	Ground
2	V _{DD}	Power supply for logic
3	V _O	Contrast Adjustment
4	C/D	Data/ Instruction select signal
5	/RD	Data read. Read data from LCD Controller
6	/WR	Data write. Write data into LCD Controller
7	DB0	Data bus line
8	DB1	Data bus line
9	DB2	Data bus line
10	DB3	Data bus line
11	DB4	Data bus line
12	DB5	Data bus line
13	DB6	Data bus line
14	DB7	Data bus line
15	/CE	Enable signal
16	/RESET	Controller reset signal, Active Low
17	V _{EE}	Negative Voltage Output
18	MD2	H: 32 columns ; L: 40 columns
19	FS1	Selection of font; H : 6 * 8 , L : 8 * 8
20	NC	No connection

Mechanical Data

Item	Standard Value	Unit
Module Dimension	144.0 x 104.0	mm
Viewing Area	114.0 x 64.0	mm
Mounting Hole	138.0 x 97.0	mm
Dot Pitch	0.45 x 0.45	mm
Dot Size	0.43 x 0.43	mm

Electrical Characteristics

Item	Symbol	Standard Value	Unit
		typ.	
Input Voltage	VDD	3/5	V
Recommended LCD Driving Voltage for Normal Temp. Version module @25°C	VDD-VO	19.5	V