

# NTG16080C1 Graphic 160x80 dots

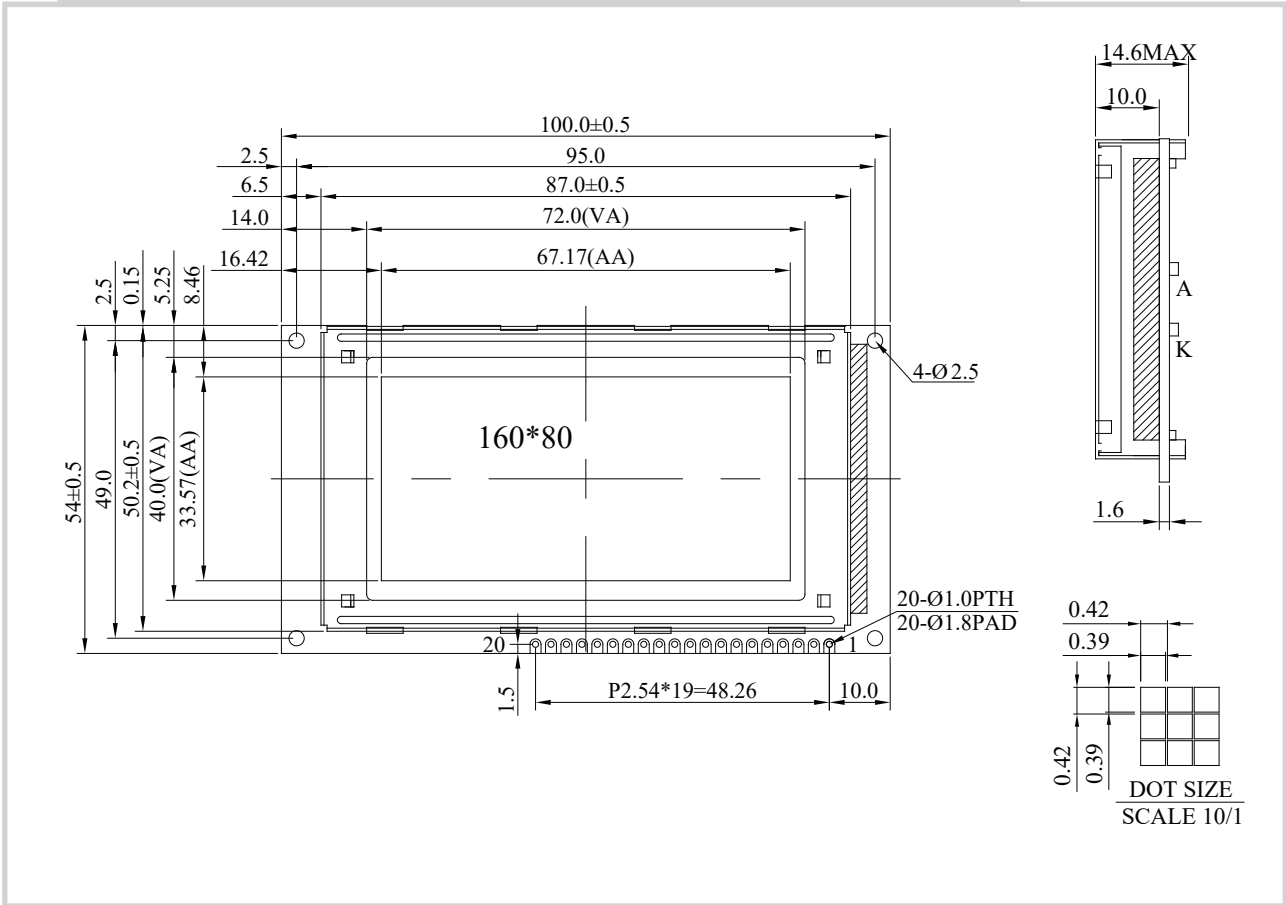

## Feature

1. 160X80 dots
2. Built-in controller RA6963
3. 3.3V / 5V power supply
4. 1/60 duty cycle
5. N.V. Built-in

Pin No.	Symbol	Description
1	V <sub>EE</sub>	Negative Voltage Output
2	V <sub>SS</sub>	Ground
3	V <sub>DD</sub>	Power supply for logic
4	V <sub>O</sub>	Contrast Adjustment
5	/WR	Data write. Write data into LCD Controller
6	/RD	Data read. Read data from LCD Controller
7	/CE	Enable signal
8	/CD	Data/ Instruction select signal
9	/RST	Controller reset signal, Active Low
10	DB0	Data bus line
11	DB1	Data bus line
12	DB2	Data bus line
13	DB3	Data bus line
14	DB4	Data bus line
15	DB5	Data bus line
16	DB6	Data bus line
17	DB7	Data bus line
18	FS	Selection of font; H : 6 * 8 , L : 8 * 8
19	A	Power supply for B/L +
20	K	Power supply for B/L -

## Mechanical Data

Item	Standard Value	Unit
Module Dimension	100.0 x 54.0	mm
Viewing Area	72.0 x 40.0	mm
Mounting Hole	95.0 x 49.0	mm
Dot Pitch	0.42 x 0.42	mm
Dot Size	0.39 x 0.39	mm

## Electrical Characteristics

Item	Symbol	Standard Value	Unit
		typ.	
Input Voltage	V <sub>DD</sub>	3/5	V
Recommended LCD Driving Voltage for Normal Temp. Version module @25°C	V <sub>DD-VO</sub>	11.5	V