

NTG160160D5 Graphic 160x160 dots

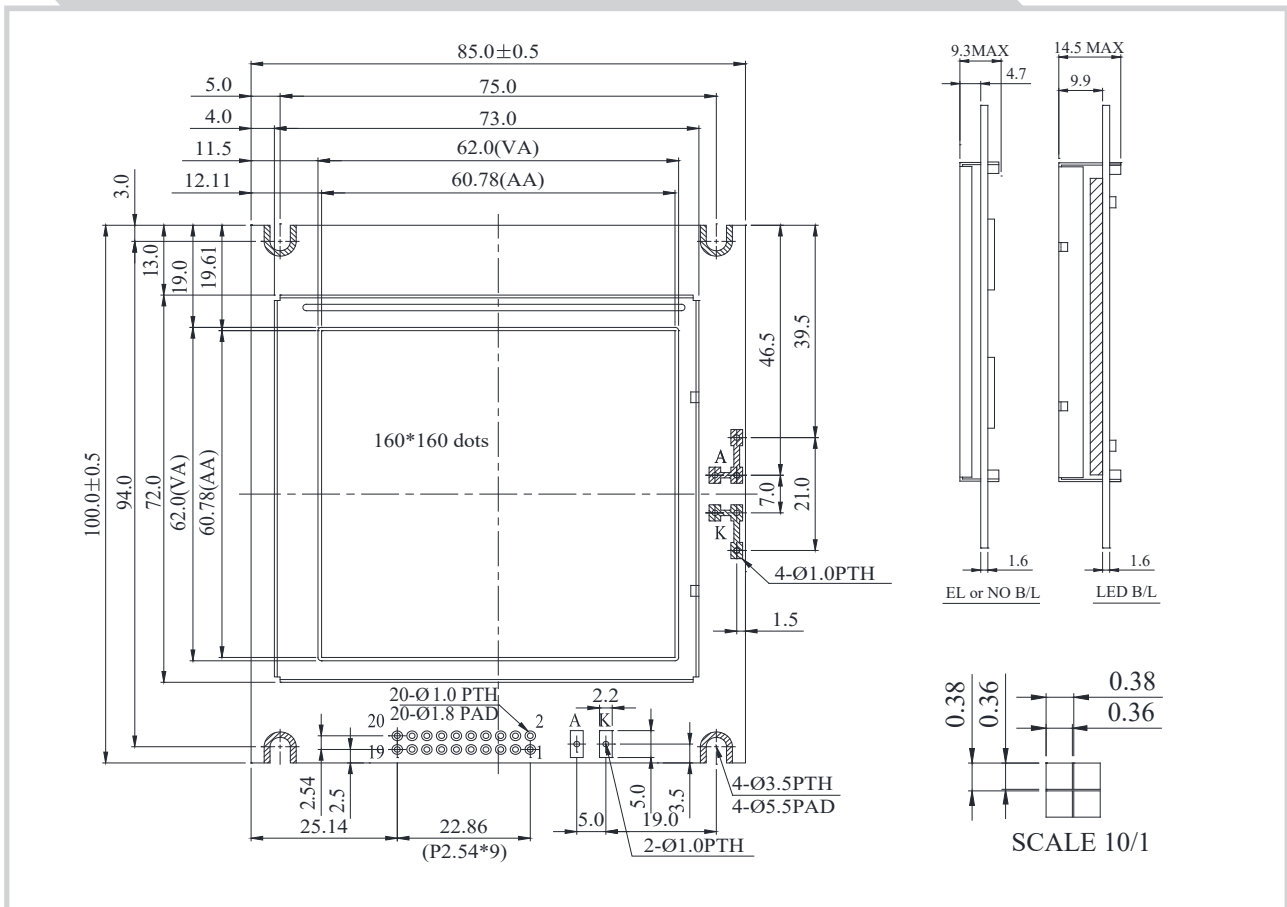

Feature

1. Built-in controller RA8822
2. 5V power supply
3. 1/160 duty cycle

Pin No.	Symbol	Description
1	FGND	Frame ground
2	VSS	Ground
3	Vdd	Power supply for logic
4	Vo	Contrast Adjustment
5	RW	Read/Write select signal
6	E	Enable signal
7	/CS	Chip select input pins
8	RS	Data/ Instruction select signal
9	BUSY	Check Busy
10	/RST	Controller reset signal, Active Low
11	DB0	Data bus line
12	DB1	Data bus line
13	DB2	Data bus line
14	DB3	Data bus line
15	DB4	Data bus line
16	DB5	Data bus line
17	DB6	Data bus line
18	DB7	Data bus line
19	NC	No connection
20	Vee	Negative Voltage Output

Mechanical Data

Item	Standard Value	Unit
Module Dimension	85.0 x 100.0	mm
Viewing Area	62.0 x 62.0	mm
Mounting Hole	75.0 x 94.0	mm
Dot Pitch	0.38 x 0.38	mm
Dot Size	0.36 x 0.36	mm

Electrical Characteristics

Item	Symbol	Standard Value	Unit
		typ.	
Input Voltage	VDD	---	V
Recommended LCD Driving Voltage for Normal Temp. Version module @25°C	VDD-VO	18.0	V